

Stock Items in carbon steel and 17-7 PH/C stainless steel. Springs listed below are 3 wave, **Overlap Type**.

Smalley Part Number ^{1,4}	Operates in Bore Diameter	Clears Shaft Diameter	Load (lb)	Work Height	Free Height ²	Number of Waves	Thickness	Radial Wall	Spring Rate ³
SSR-0050	.500	.390	7	.050	.085	3	.008	.040	200
SSR-0062	.625	.480	10	.050	.095	3	.010	.058	222
SSR-0075	.750	.500	14	.062	.160	3	.010	.078	143
SSR-0087	.875	.620	16	.062	.130	3	.012	.094	235
SSR-0100	1.000	.780	18	.062	.160	3	.012	.094	184
SSR-0112	1.125	.840	20	.078	.130	3	.016	.133	385
SSR-0125	1.250	.960	22	.078	.150	3	.016	.133	306
SSR-0137	1.375	1.090	24	.078	.190	3	.016	.133	214
SSR-0150	1.500	1.170	26	.078	.170	3	.018	.143	283
SSR-0162	1.625	1.310	28	.078	.200	3	.018	.143	230

¹ Add suffix "-S17" for 17-7 stainless steel.

² Reference dimension.

³ Theoretical dimension; measured in lb/in.

⁴ See pages 126-127 for How to Order.

OVERLAP TYPE

SSR-0050 to SSR-0162

Product Dimensions

All dimensions in inches unless otherwise specified.

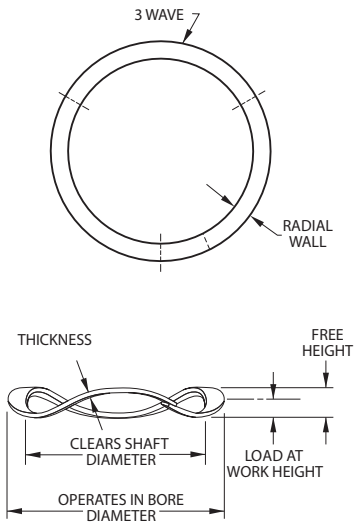

Bayonet Connector

Архангельск (8182)63-90-72
 Астана (7172)727-132
 Астрахань (8512)99-46-04
 Барнаул (3852)73-04-60
 Белгород (4722)40-23-64
 Брянск (4832)59-03-52
 Владивосток (423)249-28-31
 Волгоград (844)278-03-48
 Вологда (8172)26-41-59
 Воронеж (473)204-51-73
 Екатеринбург (343)384-55-89

Иваново (4932)77-34-06
 Ижевск (3412)26-03-58
 Иркутск (395)279-98-46
 Казань (843)206-01-48
 Калининград (4012)72-03-81
 Калуга (4842)92-23-67
 Кемерово (3842)65-04-62
 Киров (8332)68-02-04
 Краснодар (861)203-40-90
 Красноярск (391)204-63-61
 Курск (4712)77-13-04
 Липецк (4742)52-20-81

Магнитогорск (3519)55-03-13
 Москва (495)268-04-70
 Мурманск (8152)59-64-93
 Набережные Челны (8552)20-53-41
 Нижний Новгород (831)429-08-12
 Новокузнецк (3843)20-46-81
 Новосибирск (383)227-86-73
 Омск (3812)21-46-40
 Орел (4862)44-53-42
 Красноярск (391)204-63-61
 Пенза (8412)22-31-16

Пермь (342)205-81-47
 Ростов-на-Дону (863)308-18-15
 Рязань (4912)46-61-64
 Самара (846)206-03-16
 Санкт-Петербург (812)309-46-40
 Саратов (845)249-38-78
 Севастополь (8692)22-31-93
 Симферополь (3652)67-13-56
 Смоленск (4812)29-41-54
 Сочи (862)225-72-31
 Ставрополь (8652)20-65-13

Сургут (3462)77-98-35
 Тверь (4822)63-31-35
 Томск (3822)98-41-53
 Тула (4872)74-02-29
 Тюмень (3452)66-21-18
 Ульяновск (8422)24-23-59
 Уфа (347)229-48-12
 Хабаровск (4212)92-98-04
 Челябинск (351)202-03-61
 Череповец (8202)49-02-64
 Ярославль (4852)69-52-93

Киргизия (996)312-96-26-47 Казахстан (772)734-952-31 Таджикистан (992)427-82-92-69

Stock Items in carbon steel and 17-7 PH/C stainless steel. Springs listed below are 4 waves and up, **Gap Type**.

Smalley Part Number ^{1,4}	Operates in Bore Diameter	Clears Shaft Diameter	Load (lb)	Work Height	Free Height ²	Number of Waves	Thickness	Radial Wall	Spring Rate ³
SSR-0175	1.750	1.440	30	.078	.140	4	.018	.143	484
SSR-0187	1.875	1.560	32	.078	.150	4	.018	.143	444
SSR-0200	2.000	1.680	34	.093	.140	4	.024	.150	723
SSR-0212	2.125	1.800	36	.093	.150	4	.024	.150	632
SSR-0225	2.250	1.930	38	.093	.170	4	.024	.150	494
SSR-0237	2.375	1.990	40	.093	.160	4	.024	.178	597
SSR-0250	2.500	2.120	42	.093	.170	4	.024	.178	545
SSR-0262	2.625	2.240	44	.093	.190	4	.024	.178	454
SSR-0275	2.750	2.340	46	.109	.170	4	.030	.188	754
SSR-0287	2.875	2.470	48	.109	.180	4	.030	.188	676
SSR-0300	3.000	2.590	50	.109	.190	4	.030	.188	617
SSR-0312	3.125	2.710	52	.109	.210	4	.030	.188	515
SSR-0325	3.250	2.750	54	.109	.200	4	.030	.233	593
SSR-0337	3.375	2.840	56	.109	.220	4	.030	.233	505
SSR-0350	3.500	3.000	58	.109	.230	4	.030	.233	479
SSR-0362	3.625	3.120	60	.109	.240	4	.030	.233	458
SSR-0375	3.750	3.250	62	.109	.260	4	.030	.233	411
SSR-0387	3.875	3.370	64	.109	.300	4	.030	.233	335
SSR-0400	4.000	3.500	66	.109	.190	5	.030	.233	815
SSR-0412	4.125	3.620	67	.109	.200	5	.030	.233	736
SSR-0425	4.250	3.740	69	.109	.210	5	.030	.233	683
SSR-0437	4.375	3.860	70	.109	.210	5	.030	.233	693
SSR-0450	4.500	3.990	72	.109	.230	5	.030	.233	595
SSR-0462	4.625	4.110	73	.125	.270	5	.030	.233	503
SSR-0475	4.750	4.240	75	.125	.310	5	.030	.233	405
SSR-0487	4.875	4.370	76	.125	.290	5	.030	.233	461
SSR-0500	5.000	4.490	78	.125	.310	5	.030	.233	422
SSR-0512	5.125	4.610	80	.125	.340	5	.030	.233	372
SSR-0525	5.250	4.740	82	.125	.370	5	.030	.233	335
SSR-0537	5.375	4.860	84	.125	.380	5	.030	.233	329
SSR-0550	5.500	4.990	86	.125	.250	6	.030	.233	688
SSR-0562	5.625	5.110	88	.125	.270	6	.030	.233	607
SSR-0575	5.750	5.240	90	.125	.280	6	.030	.233	581
SSR-0587	5.875	5.360	92	.125	.300	6	.030	.233	526
SSR-0600	6.000	5.490	94	.125	.300	6	.030	.233	537
SSR-0612	6.125	5.610	96	.125	.310	6	.030	.233	519
SSR-0625	6.250	5.730	98	.125	.340	6	.030	.233	456
SSR-0637	6.375	5.860	100	.125	.350	6	.030	.233	444
SSR-0650	6.500	5.980	102	.125	.390	6	.030	.233	385
SSR-0675	6.750	6.230	104	.125	.420	6	.030	.233	353
SSR-0700	7.000	6.160	106	.156	.320	6	.032	.375	646
SSR-0725	7.250	6.440	108	.156	.350	6	.032	.375	557
SSR-0750	7.500	6.690	110	.156	.360	6	.032	.375	539
SSR-0775	7.750	6.940	114	.156	.380	6	.032	.375	509
SSR-0800	8.000	7.190	118	.156	.390	6	.032	.375	504
SSR-0825	8.250	7.440	122	.156	.430	6	.032	.375	445
SSR-0850	8.500	7.680	126	.156	.340	7	.032	.375	685
SSR-0875	8.750	7.930	130	.156	.340	7	.032	.375	707
SSR-0900	9.000	8.180	134	.156	.290	8	.032	.375	1,000
SSR-0950	9.500	8.680	142	.156	.240	9	.032	.375	1,690
SSR-1000	10.000	9.170	150	.156	.290	9	.032	.375	1,119
SSR-1050	10.500	9.670	158	.156	.310	9	.032	.375	1,026
SSR-1100	11.000	10.170	166	.156	.350	9	.032	.375	856
SSR-1150	11.500	10.660	174	.156	.360	9	.032	.375	853
SSR-1200	12.000	11.160	182	.156	.440	9	.032	.375	641
SSR-1250	12.500	11.660	190	.156	.350	10	.032	.375	979
SSR-1300	13.000	12.160	198	.156	.410	10	.032	.375	780
SSR-1350	13.500	12.650	206	.156	.430	10	.032	.375	752
SSR-1400	14.000	13.150	214	.156	.300	12	.032	.375	1,486
SSR-1450	14.500	13.650	221	.156	.320	12	.032	.375	1,348
SSR-1500	15.000	14.130	230	.156	.350	12	.032	.375	1,186
SSR-1550	15.500	14.640	239	.156	.310	13	.032	.375	1,552
SSR-1600	16.000	15.140	248	.156	.340	13	.032	.375	1,348

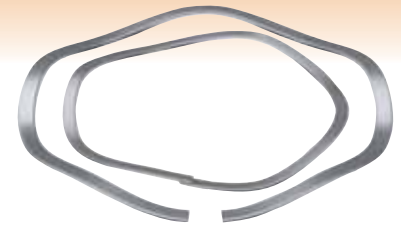

GAP TYPE

SSR-0175 to SSR-1600

Product Dimensions

All dimensions in inches unless otherwise specified.

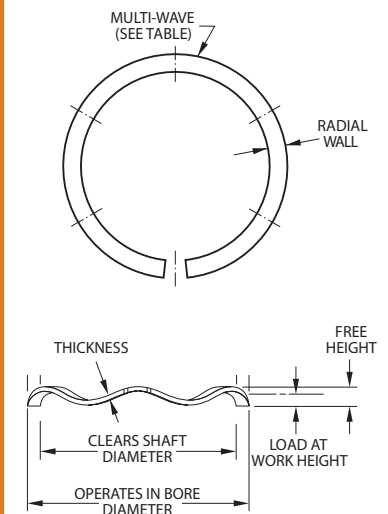

¹ Add suffix "-S17" for 17-7 stainless steel.

² Reference dimension.

³ Theoretical dimension; measured in lb/in.

⁴ See pages 126-127 for How to Order.

SSR-N Series Narrow Section Wave Springs

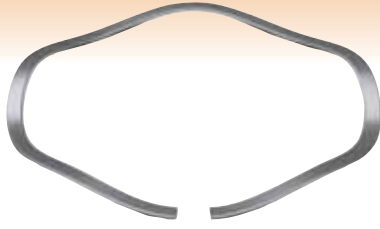

Smalley narrow section wave springs were originally designed to pre-load packings in telescoping hydraulic cylinders. They have also found other applications where working space is highly limited. This Smalley Wave Spring series is designed to fit into a bore with a light snap to assure perfect concentricity between the wave spring and assembly. When these narrow section wave springs are compressed, radial expansion is taken up by the gap in the spring to eliminate binding.

Stock Items in carbon steel and 17-7 PH/C stainless steel. Springs listed below are 4 waves and up, **Gap Type**.

Smalley Part Number ^{1,4}	Operates in Bore Diameter	Clears Shaft Diameter	Load (lb)	Work Height	Free Height ²	Number of Waves	Thickness	Radial Wall	Spring Rate ³
SSR-0325-N	3.250	2.820	54	.109	.200	4	.030	.188	593
SSR-0337-N	3.375	2.940	56	.109	.220	4	.030	.188	505
SSR-0350-N	3.500	3.070	58	.109	.260	4	.030	.188	384
SSR-0362-N	3.625	3.190	60	.109	.270	4	.030	.188	373
SSR-0375-N	3.750	3.320	62	.109	.280	4	.030	.188	363
SSR-0387-N	3.875	3.440	64	.109	.310	4	.030	.188	318
SSR-0400-N	4.000	3.570	66	.109	.200	5	.030	.188	725
SSR-0412-N	4.125	3.690	67	.109	.200	5	.030	.188	736
SSR-0425-N	4.250	3.820	69	.109	.240	5	.030	.188	527
SSR-0437-N	4.375	3.940	70	.109	.210	5	.030	.188	693
SSR-0450-N	4.500	4.070	72	.109	.280	5	.030	.188	421
SSR-0462-N	4.625	4.190	73	.125	.270	5	.030	.188	503
SSR-0475-N	4.750	4.320	75	.125	.320	5	.030	.188	385
SSR-0487-N	4.875	4.440	76	.125	.320	5	.030	.188	390
SSR-0500-N	5.000	4.570	78	.125	.350	5	.030	.188	347
SSR-0512-N	5.125	4.690	80	.125	.350	5	.030	.188	356
SSR-0525-N	5.250	4.820	82	.125	.360	5	.030	.188	349
SSR-0537-N	5.375	4.940	84	.125	.440	5	.030	.188	267
SSR-0550-N	5.500	5.070	86	.125	.280	6	.030	.188	555
SSR-0562-N	5.625	5.190	88	.125	.290	6	.030	.188	533
SSR-0575-N	5.750	5.320	90	.125	.340	6	.030	.188	419
SSR-0587-N	5.875	5.440	92	.125	.340	6	.030	.188	428
SSR-0600-N	6.000	5.570	94	.125	.340	6	.030	.188	437
SSR-0612-N	6.125	5.690	96	.125	.280	7	.030	.188	619
SSR-0625-N	6.250	5.820	98	.125	.280	7	.030	.188	632
SSR-0637-N	6.375	5.940	100	.125	.300	7	.030	.188	571
SSR-0650-N	6.500	6.070	102	.125	.300	7	.030	.188	583
SSR-0675-N	6.750	6.320	104	.125	.300	7	.030	.188	594
SSR-0700-N	7.000	6.480	106	.156	.320	7	.030	.233	646
SSR-0725-N	7.250	6.730	108	.156	.330	7	.030	.233	621
SSR-0750-N	7.500	6.980	110	.156	.360	7	.030	.233	539
SSR-0775-N	7.750	7.230	114	.156	.380	7	.030	.233	509

GAP TYPE

SSR-0325-N to SSR-0775-N

Product Dimensions

All dimensions in inches unless otherwise specified.

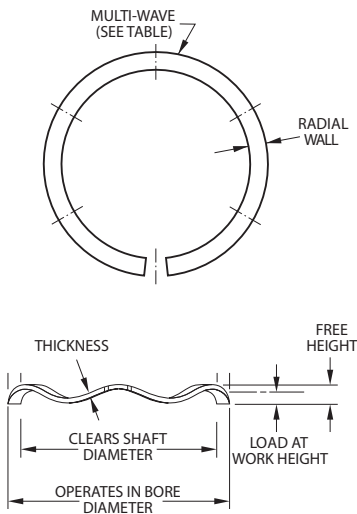

¹ Add suffix "-S17" for 17-7 stainless steel.

² Reference dimension.

³ Theoretical dimension; measured in lb/in.

⁴ See pages 126-127 for How to Order.

Архангельск (8182)63-90-72
Астана (7172)727-132
Астрахань (8512)99-46-04
Барнаул (3852)73-04-60
Белгород (4722)40-23-64
Брянск (4832)59-03-52
Владивосток (423)249-28-31
Волгоград (844)278-03-48
Вологда (8172)26-41-59
Воронеж (473)204-51-73
Екатеринбург (343)384-55-89

Иваново (4932)77-34-06
Ижевск (3412)26-03-58
Иркутск (395)279-98-46
Казань (843)206-01-48
Калининград (4012)72-03-81
Калуга (4842)92-23-67
Кемерово (3842)65-04-62
Киров (8332)68-02-04
Краснодар (861)203-40-90
Красноярск (391)204-63-61
Курск (4712)77-13-04
Липецк (4742)52-20-81

Магнитогорск (3519)55-03-13
Москва (495)268-04-70
Мурманск (8152)59-64-93
Набережные Челны (8552)20-53-41
Нижний Новгород (831)429-08-12
Новокузнецк (3843)20-46-81
Новосибирск (383)227-86-73
Омск (3812)21-46-40
Орел (4862)44-53-42
Оренбург (3532)37-68-04
Пенза (8412)22-31-16

Пермь (342)205-81-47
Ростов-на-Дону (863)308-18-15
Рязань (4912)46-61-64
Самара (846)206-03-16
Санкт-Петербург (812)309-46-40
Саратов (845)249-38-78
Севастополь (8692)22-31-93
Симферополь (3652)67-13-56
Смоленск (4812)29-41-54
Сочи (862)225-72-31
Ставрополь (8652)20-65-13

Сургут (3462)77-98-35
Тверь (4822)63-31-35
Томск (3822)98-41-53
Тула (4872)74-02-29
Тюмень (3452)66-21-18
Ульяновск (8422)24-23-59
Уфа (347)229-48-12
Хабаровск (4212)92-98-04
Челябинск (351)202-03-61
Череповец (8202)49-02-64
Ярославль (4852)69-52-93

Киргизия (996)312-96-26-47 Казахстан (772)734-952-31 Таджикистан (992)427-82-92-69

<http://smalley.nt-rt.ru> || sym@nt-rt.ru